



Outdoor Microphone Protection

For community, construction, mining, aircraft or other outdoor noise monitoring

Highlights

- Microphone Protection in any weather
- Use with any ½ inch microphone and preamplifier*
- Built in water repellent barrier (rain hat)
- Flexible mounting options
- IEC 61672 Class 1 compliant when used with Model 831 or LxT
- Easy microphone calibration
- Desiccants included
- Fully characterized with
 - 0°, 90°, and random response
 - Wind Noise Reduction

Applications

- Outdoor Noise Monitoring
- Construction Noise
- Mining Noise
- Aircraft Noise
- Amusement Parks
- Environmental Impact Studies
- Industrial Noise Monitoring
- Night Clubs
- Concerts
- Motorsports



Model EPS2116

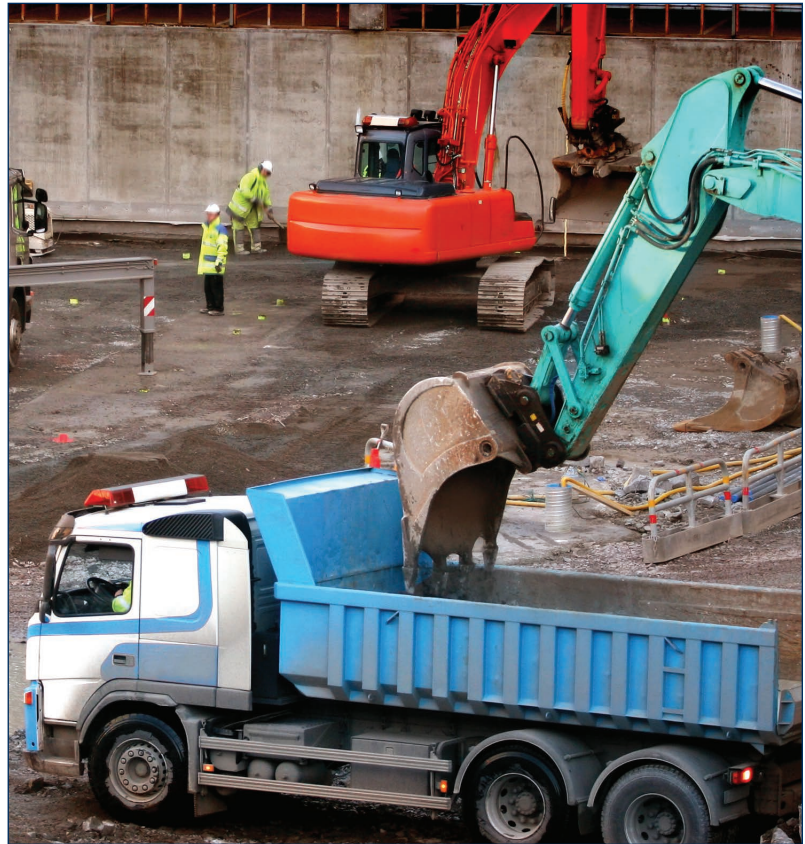

When making outdoor noise measurements, sensitive microphones and equipment can be exposed to all types of weather including rain, dew, wind and heat. Protect your microphones from potentially adverse environment conditions that can lead to incorrect measurement by using the EPS2116.

The EPS2116 is designed to work with almost any combination of ½ inch precision microphone and preamplifier* and provides for easy acoustic calibration to make sure your measurements are accurate. Because the EPS2116 is designed with an integral rain shield it will keep your microphone dry even in a driving rain.

Combine the EPS2116 with the Larson Davis PRM2103-FF outdoor microphone and Model 831 sound level meter to produce an ideal outdoor noise measuring system that will work in a wide variety of climates, without the need for desiccants and with minimal routine maintenance. When combined with the PRM2103-FF the integrated heater eliminates the need for desiccants and the remote calibration check minimizes routine maintenance.

* The PCB 378 series products are not recommended for outdoor use with the EPS2116



EPS2116 Environmental Protection System

Acoustical Frequency Response (typical)

Data shown includes effects of Model 831 EPS2116 correction filters

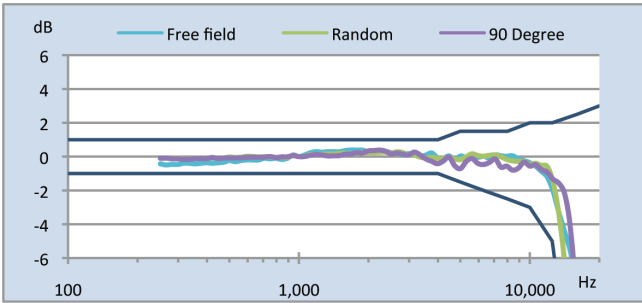

Environmental Specifications

Operating Temperature	- 40 °F to 158 °F (- 40 °C to 70 °C)
Operating Humidity	0 to 100% relative humidity
Wind	Wind induced noise

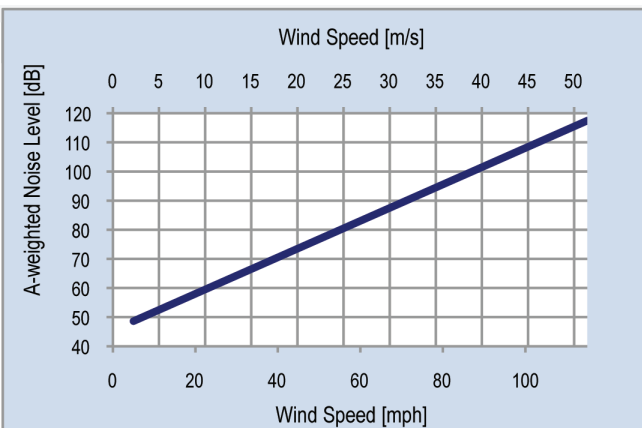

Physical

Diameter	1.6 in (41 mm) – Body 3.0 in (76 mm) - Windscreen
Height	15.8 in (40 cm) 16.8 in (43 cm) with ¼ - 20 adapter
Venting	Bottom of preamplifier by connector
Mounting	¾ in NPT (Pipe Thread R ¾) ¼ - 20 camera thread using included ADP103 adapter 1.5 in (38 mm) speaker stand using included adapter
Weight	0.71 lb. (332 g)
Materials	UV resistant
Desiccants	Included – tubular type

Compliance

IEC 61672-1 (2002) Class 1 and ANSI S1.40-1984*

IEC 61010-1 (2001) Safety

ROHS & CE

*When used with Model 831 or LxT and appropriate connection filter



3425 Walden Avenue, Depew, NY 14043-2495 USA

Phone 716-926-8243

Toll-Free in USA 888-258-3222

Fax 716-926-8215 E-mail sales@larsondavis.com

Web Site www.larsondavis.com

ISO 9001 CERTIFIED

© 2016 PCB Group, Inc. In the interest of constant product improvement, specifications are subject to change without notice. PCB, and ICP are registered trademarks of PCB Group Inc., SoundTrack LXT, Spark and Blaze are registered trademarks of PCB Piezotronics, Inc. HV Manager is a trademark of PCB Piezotronics, Inc. All other trademarks are property of their respective owners.

LD-Model-ESP2116-0116

Printed in U.S.A.

Supported Preamplifiers (Typical)

PRM2103	Outdoor Preamplifier for Model 831
PRM831	Standard Model 831 preamplifier
PRMLXT1 & 1L	Standard SoundTrack LxT1 preamplifier
PRMLXT2 & 2L	Standard SoundTrack LxT2 preamplifier

Optional Accessories

TRP001	Camera type tripod
TRP003	Portable tripod
TRP019	Permanent, tilt-down pole use with ADP100
TRP020	Semi-permanent tripod use with ADP100
WS011	Replacement windscreen
ADP100	Adapter connecting EPS2116 to TRP019 or TPR020
DSC003	Replacement desiccant cartridges

Ordering Information

EPS2116	Environmental Protection System for ½ inch microphones and preamplifiers
---------	--

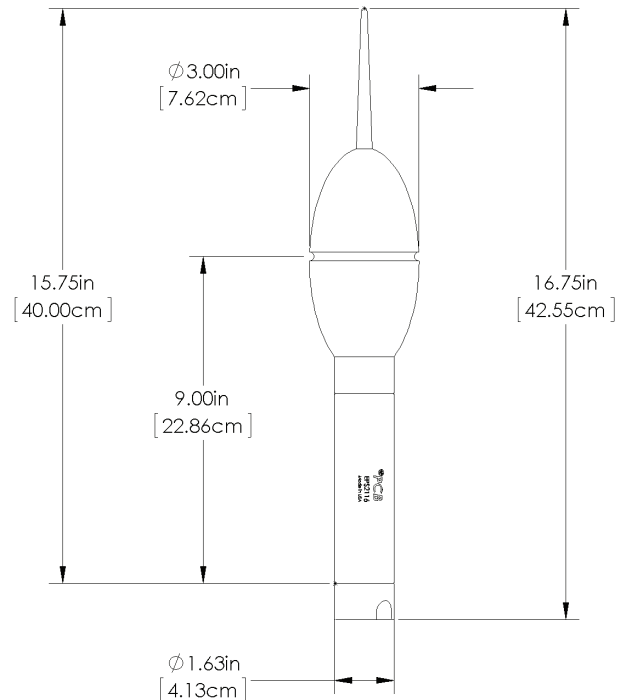

Model EPS2116 Dimensions

For environmental noise monitoring and building acoustics, **Larson Davis** offers a full line of instruments, accessories and software. For personal noise and vibration exposure monitoring, Larson Davis complements this with sound level meters, personal noise dosimeters, human vibration meters, audiometric calibration systems and hearing conservation programs.

Visit www.larsondavis.com to locate your nearest sales office